

JAPAN &
It's Future
After
The
LDP!



The Last throes
OF A 26 year
Economic Depression
2016

ACKNOWLEDGEMENTS

I would like to thank the many people who have been writing from around the world. It is encouraging to know that there are so many people who are interested in uncovering the truth. I have also special thanks for so many providing valuable insight into trends around the world from China, Soviet Republics, South Africa, Brazil, Australian, and India. I believe we can survive the folly of governments even if they refuse to listen. The key is understanding the nature of events, and that allows us to correctly make the decision to be on the opposite side.

I would like to also thank all my old friend and former clients for their support and to know that they have continued to gather information that serves us all in times of crisis.

We are standing on the precipice of a new era in global-social-economics. How we enter this new age is of critical importance. Government is incapable to doing anything for any reform of its own abuse of power is not up for negotiation. We must weather the storm, and to do so we need to understand its nature. Just as the 1930s Great Depression set in motion profound changes that were even manifest in geopolitical confrontations, we have now reached such a crossroads. A debt crisis has its tentacles deeply embedded into every sector right into government. This is the distinction from a mere stock market crash that never alters the economy long-term. We are seriously still over-leveraged and some banks are still trying to be hedge funds and have to speculate to make a profit. That is a key warning sign that the worse is yet to come.

Comments, Suggestions & Questions

Please mail to:

Martin A. Armstrong
FCI Fort Dix Camp, #12518-050
PO Box 2000
Fort Dix, NJ 08640

PLEASE REGISTER YOUR EMAIL ADDRESS
FOR FUTURE UPDATED NEWS CRITICAL TO OUR SURVIVAL

ArmstrongEconomics@GMail.COM

Copyright, Martin A. Armstrong, all rights reserved

This Report may be forwarded as you like without charge to individuals or governments around the world. It is provided as a Public Service at this time without cost because of the critical facts that we now faced economically. The contents and designs of the systems are in fact copyrighted. At a future date, a new edition of the 1986 The Greatest Bull Market In History will be released and a new book will soon be published on the model itself - The Geometry of Time. It is vital that we do not forget this is a world economy and the arrogance that any nation can dictate to the world is just insanity. Every nation effects all others no different than if one nation were to pour all its toxic waste into the ocean. Everything is interlinked and solutions are never isolated events.

JAPAN & Its future
After the LDP!

The Last
throes of A
26 year ECONOMIC
DEPRESSION
2016



by: Martin A. Armstrong

Former Chairman of Princeton Economics International, Ltd.
and the Foundation For The Study of Cycles

TIME

no different than the drug dealers, and they are destroying our future for their own self-interests. Because the New York investments banks control the courts, the very federal government and have infiltrated central banks, World Bank, and the IMF, they have a lot at stake to ensure that the status quo remains intact. They will curse me no doubt just like the manufacturers of horse whips and buggy manufacturers were cursing the fanggled automanufacturers who were robbing them of their monopoly.

Government is also desperate to stop the exploration of time just as the Catholic Church was against science and Galileo for daring to claim that the earth revolved around the sun and imprisoned him for life for making such claims. Kondratieff was imprisoned for his exploration of cycles and when his prison term was up, they just came up with new charges, sentenced him one more time, but they took him out back and shot him to solve the problem of ever having to deal with releasing him. And then there was Socrates who had the courage to even question the existence of all these gods of the state, and they ordered him to be just executed for corrupting the minds of the youths.

is truly the next frontier. It is a whole new dimension that can no longer be ignored. There are powerful forces that seek to stop any attempt to explore time. There are the traditional investment banks who are desperate to keep things as they are, for they have the vested interest in keeping government addicted to borrowing so they can remain as the sellers

Government, no matter what its pretended form, is always the same be it a Democracy, Communistic State, Dictatorship, or some magnanimous monarchy. As Thrasymachus pointed out, all states only enact laws in their own self-interest. Therefore, justice they claim is the prosecution of anyone who disagrees with them. So justice is the same everywhere and in all forms of government. It is only the self-interest of the state -- nothing more.

The exploration of TIME exposes perhaps a new way of approaching society. One that actually allows us to retain knowledge rather than discard it and start over each and every time making the same mistakes perpetually.



Minamoto Yoritomo
(1147-1199 AD)



Ashikaga Tadayoshi
(1306-1352 AD)



Tokugawa Ieyasu
(1543-1616 AD)

In March of 1999, I delivered a major forecast in Tokyo that to the Japanese was earth-shattering. I dared to warn that the unbeatable LDP (Liberal Democratic Party) was entering a downward spiral from which it would lose power. Forget the markets. What I publicly forecast was like attacking God himself. There were literally gasps I heard in the audience.

The LDP was unbeatable and had become known at the "1955 System." What the West cannot appreciate is how religious belief in Japan shaped the name, and the famed Kamikaze pilots of World War II flying their planes directly to crash into ships, was all a part of culture. Kamikaze means the "Divine Wind" and it was perhaps first used in terms of war when the Mongol fleets were leaving from Korea to attack and invade Japan in 1274 and 1281, but were destroyed by typhoons that became the "Divine Wind" that protected Japan.

The legendary tradition of the birth of Japan extends back to 607BC with the reputed accession of the first emperor, Jimmu whose expedition eastward from Hyuga in 607BC along the inland sea, subduing tribes on his journey that ended at Yamato where he established his centre of power. This period was believed to have been prosperous and his domain also included parts of Korea.

While some historians disagree with the dates and prefer the early period AD rather than BC, nevertheless, it is here that Jimmu is said to have been a descendant of the sun goddess Amaterasu through the celestial grandson Ninigi, whom she sent down to earth from above. He married yet another who was to be the descendant of the storm god Susanoo. This is the origin of the belief that the emperor of Japan was a son of God on earth. When MacArthur entered Japan at the end of the war, the Japanese troops turned their back toward him. He was at first insulted. It had to be explained to him, he had just conquered God. It is this tradition that the LDP assumed the mantle of near divinity.

When I would meet a elderly gentleman in Japan who was clearly of that vintage, I would greet him with the old language, not the modern Japanese. It was a sign of respect and they knew that I understood the very different cultural beliefs. I would enter into some very deep conversations. When they knew I understood the history of Japan, they would confide in me they still believed the emperor was the son of God.

So to even forecast the decline of the LDP was a daring move in Japan. Some of our staff in Japan believe I made a mistake even to attempt to forecast such a thing in Japan. Markets were one thing - the LDP another.

As with the cyclical nature of all things, the Jimmu dynasty at Yamato had rocketed into power. It was sort of a spike high in charting but it began to decline and with its decline opened the door for the entry of Buddhism to Japan from China via Korea. The Japanese then began to absorb culture from China that had included the Chinese writing system during this period.

Japan would oscillate over the centuries between opening to the world and isolationism. We see the first isolationism emerging during the 9th Century as ties with China were then severed. This began a unique trend in both the Japanese language where the style and the pronunciation of words became strikingly very different from Chinese although the same word in written form often retained the same general meaning in both places. Yet we also see a very different and unique version of Japanese Buddhism developed as well thanks to this period of isolationism.

The emperors of Japan for the most part became subordinated to the powerful family organizations that were emerging. Such families emerged as warrior families in the provinces that was leading toward a military class not unlike the difference between Athens and the military oligarchy of Sparta.

In 1192, the samurai Minamoto Yoritomo defeated a rival and established in his wake the first military government in Japan that is popularly known as a shogunate located at Kamakura. This is the general formation of the political structure of Japan that thereafter controlled for the most part until 1867 with noted exceptions of a brief periods of feudalism and civil wars.

It was during this first Kamakura Shogunate (1192-1333) that we find the Mongol invasions that launched against Japan from Korea in 1274 and 1281. The Mongols were crushed by sudden typhoons and were then to be known as "Kamikaze" meaning "Divine Wind" that had protected Japan. But the military expenditures to prepare for this invasion were so costly, this is where we find the first great economic depression. So bad was this loss of capital formation, that it led to the collapse of the Kamakura Shogunate

There appears to be a Pi cycle of pure economic devastation, and a brief period of where government itself effectively ceased to exist. The new succeeding shogunate was

a reorganization of government that is known as the Muromachi period under the Ashikaga shoguns who seized control 1338 and held the reigns of power until 1573.

Ashikaga Takauji (1305-1358) effectively established his ruling power when in 1335 during July, he used the opportunity to take control and there were many who envied the Ashikaga family and accused them of murdering a prince and rewarding their own people without imperial approval. For you see, the shogunate was not the emperor, but the military power. These allegations led to all out war, and thus the Ashikaga family emerged victorious.

The period known as Muromachi, however, was short lived, in the sense of peace and unity. There were effectively multiple emperors, for the first had fled and set up court in the north. The stability was thus questionable and after one cycle of 224 years, the period spiralled down in effectively just one 8.6 year collapse. This was followed by a Pi cycle of 31.4 years of conflict and a effort to try to unify Japan began by Oda Nobunaga. Toyotomi Hideyoshi continued the effort of unification in 1590. However, that did not come until his death in 1598.

It was at the Battle of Sekigahara in 1600 where Tokugawa Ieyasu defeated all his military rivals and thus begins shortly thereafter, the Tokugawa Shogunate (1603-1867) that was marked by yet another swing back to isolationism. We find that a Jesuit Francis Xavier had landed in Japan in 1549 and began his quest to convert the island to christian values. We find, therefore, under the new Tokugawa Shogunate, the first christian persecution in Japan. This period of such isolationism was also marked by forbidding any Japanese to even travel abroad.

While the Tokugawa Shogunate was a period of nearly 200 years of peace within Japan, it had created a backward society, froze progress that led to both a cultural and economic stagnation. This period of internal peace, ironically led to making the samurai pointless. What was gradually taking place was the samurai were being displaced by merchants. There were clear black markets whereas official trade was prohibited by law.

Hence, the peace bred a new class of merchants and this would be the seeds of

Japan & Its 224 Year Cycle of Political Change

Kamakura Wave

Muromachi Wave

Tokugawa Wave

Meiji Wave

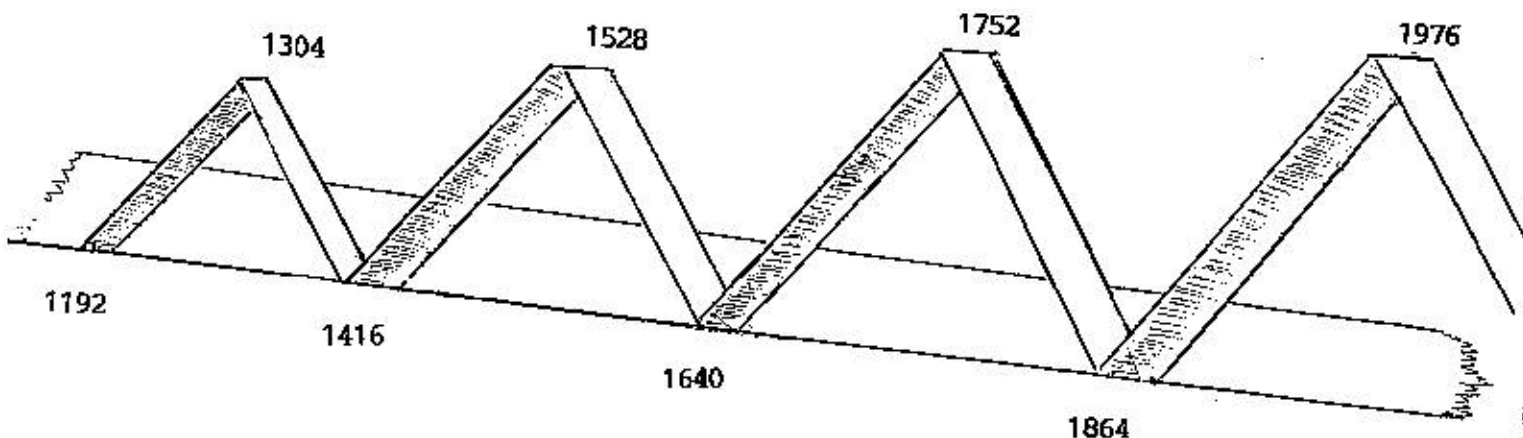

the very destruction of the Tokugawa Shogunate by 1867. When the Tokugawa Shogunate could no longer keep the European and American traders away, its support among the people simply just imploded. People wanted trade. They wanted new ideas and new products. They craved change and progress itself.



Meiji Tenno (1852 - 1912 AD)

The Emperor Meiji was coronated in 1868 and for the first time, he assumed real power and absolute rule. The age of puppet emperors controlled by military warlords (shoguns) was now over. The people were impressed with the west as was Meiji and he embarked upon a course of modernization in Japan that has led to its rise today being the second largest economy in the world. He abolished the feudal land system in 1871. He created education in a new school system in 1872. He adopted a cabinet system of government in 1885, and he created a constitution in 1889 opening the

Diet in 1890. However, Meiji also seems to have absorbed the imperialistic visions of empire from the west as well. He played an active role in the Sino-Japanese War (1894-1895) followed by the war with Russia known as the Russo-Japanese War (1904-1905), and in 1910, he annexed Korea to Japan.

Meiji thus introduced western culture from clothing, he himself wore, right down to everything from art to military conquest. He is said to have composed 100,000 poems in his lifetime.

It is against this backdrop to history that perhaps you can begin to understand what sparked the Japanese military conquest, as well as what came after Meiji, when he was succeeded by the crown prince Yoshihito who became known as Taisho Tenno who became the 123rd ruling emperor of Japan in 1912 and ruled until 1926. He had continued the Meiji policy of modernization and he became a very congenial friend of both the United States and Great Britain.

The next emperor became Hirohito who assumed the throne in 1926. As crown prince, he was the first such royalty of Japan to travel to Europe in 1921. He assumed the throne when his father became mentally ill and could not preside as emperor. However, the rise of military interests began during his father's reign and when he came to the throne, he found himself very much dominated as the old practices of the shoguns. There was sincere arguments that he had opposed the war and the alliance with Germany. Of course there were those who just hated him no matter what in the West. But he broke the imperial silence in 1945 to announce to his-

people in a radio broadcast on August 15th, 1945, that Japan would accept the Allies' terms of surrender.



Hirohito (1901 - 1989 AD)

Emperor Hirohito broke all tradition once again with a second radio address on January 1st, 1946 when he publicly there and then repudiated the historical quasi-divine status of Japanese emperors. Under the new Japanese constitution, Japan became a more traditional British form of democratic monarchy whose powers were constrained purportedly to bring the imperial family closer to the real people of Japan.

I hope that this brings Japan into a better focus, for what lies ahead, may be strange without understanding the historical background. We will see more than just a political change in the winds. We will see that Japan will also gravitate toward a new period of more closer nationalistic views of isolationism. The bitter taste of the LDP and its total mismanagement of the economy is to blame for the lost decade and much, much more.

Tradition in Japan was still very much as if the LDP were monarchy itself. When the economic collapse was unfolding in Japan, the Western brokers were bailing out. Even the Merrill Lynch was closing its doors. The LDP was now concerned that this would appear as protectionism. Princeton was then asked by the Japanese government buy Cresvale, owned by a French bank who was a underwriter of many Japanese corporate bonds,

Princeton had been providing research in Japan and we had a separate operation there headed up by a very dear friend of mine, Jack King. The government then asked a favor that we buy Cresvale in 1995. Becoming a broker-dealer was the furthest from my list of goals in life.

Tradition in Japan was dominating. When the government asked such a "favor" it was like the movie Godfather. It was one of those offers one cannot refuse and continue to do business in Japan.

I discussed the matter with friends in Japan, and was told, I really had no choice. The deal was then done. Princeton came to the rescue and bought Cresvale. The government was pleased, and we rose in stature in Japan even in brokerage fees. But Cresvale was also a underwriter of Japanese corporate debt. So the only choice I had, was to expand the entity and to then take it public to get out of the broker business. That we did, opening up offices in Europe to Australia. We were preparing to be the first on-line global brokerage house in the world. I hired a team of programs in Asia and they worked in our Hong Kong office building the first huge international online system. We even had the first approval to accept on-line electronic signatures from the British authorities.

We had a huge company meeting in January 1999 in Tokyo. Every office flew in. The war plan was laid out and we would go public with Cresvale. During the negotiations with investment bankers, they wanted the whole ball of wax, not just Cresvale. They wanted to take Princeton public.

This is the backdrop to doing business in Japan when the LDP was in charge. It may have been an elected government, but it in fact acted much closer to an autocratic type government.

When the LDP sealed its own fate, they interfered with the economy at every level. Political figures would retire to cushy jobs in the private sector. They were considered gods in themselves. One such official took up office at Yakult. The management was just disastrous because direction was being taken from the government. I would often argue that the Nikkei would collapse. The response from Mr. Kumagai was that the government would not allow that. When I told him he would lose, it was ignored. When the Nikkei didn't hold the 30,000, or the 20,000 levels, then my words started to hit home. But now the government wanted us to participate in a bailout buying portfolios at face value, selling the assets, and pay off the note whenever possible. The companies were relieved of having to report the loss and each note was approved by the Japanese Ministry of Finance.



Tojo Hideki (1884 - 1948 AD)

President John Quincy Adams remarked as he left office about how the Republicans had triumphed and displaced the Federalists - We have conquered the enemy. We have occupied their hill. We have become the enemy.

Throughout history, he who conquers the enemy, always becomes the very same thing that they fought to destroy. Napoleon led the battle against the French Monarchy. He eventually crowned himself emperor. The US revolted against the tyranny of the king and Jefferson noted in the Declaration of Independence how the king used procedure to deny the people trial by jury. Today, once charged in a federal court, you are threatened with 2 to 5 times the sentence if you go to trial. They also allow judges to in fact overrule the jury if you beat 9 out of 10 charges, the judge will still sentence you for those 9 charges and claim he is not a jury and thus does not have to find you guilty beyond a reasonable doubt, just if he personally believes it was more like than not that the jury was mistaken. The right to a jury trial no longer exists in federal courts.

Jefferson also listed among the injuries that the king protected his agents with mock trials for injuries against the people and would protect them at all costs. Today, all judges and prosecutors have absolute immunity and they cannot be sued. Judge John M. Walker (Bush's cousin), ran over a cop directing traffic on his way home and killed him. He was not even tested for drunk driving and let go. There is no one, not even the widow of a dead cop, who has any respect for their loss in the United States.

The point is simply this. No matter what the government, it always reverts back to the very thing the claimed revolution or political change was all about. To the left, you will see the picture of Tojo Hideki who was the prime minister of Japan during World War II and was also a military leader and the true architect of the war. Note that he was in fact a military figure, who also assumed the roll of prime minister. This was the same as it had always been through history - a shogun who subordinated the emperor. Only Emperor Meiji had broken that subordination. But upon his death, the new modern form of shogun rose as the military form of government.

What Was Before Is Always Again!

Tojo Hideki was tried and executed for war crimes. Nevertheless, the American version of the Constitution subordinated the emperor once again officially, believing that somehow we will end up with a real democracy. The fact that the people were traditionally still also subordinated to central power, despite the mere elections, the people merely voted with the slate of the government - the LDP.

The LDP operated the same as a dictator in any third world country. They subordinated the entire economy and every little thing right down to gloves worn by a cab driver were indeed regulated. The culture of the old shogun had not died. It was merely recast in a new modern form of pretended democracy.

The economic collapse of Japan was the direct result of this over-regulation that destroyed the free markets no different than the communists did in dictating their economic activity of their people.

The LDP turned, like the United States is doing now charging brokers at UBS & Credit Swiss but no US bankers, against foreign brokers. The first was to create the FSA a new agency and their role was to blame westerners. They began with Credit Swiss and accused the bank of aiding Japanese corporations and banks to use derivatives to hide their losses. Credit Swiss had its banking license revoked. Our notes were in fact drafted by Credit Swiss. So Princeton became the next target. Despite the fact that each note was approved by the Ministry of Finance on each deal, Japan was now starting its new isolation period and to shift blame to westerners.

Before the high in December 1989, I had flown to Japan and met with both the two largest portfolios perhaps in the world at that time. I did not realize the size of any Japanese portfolios prior to that trip. I met with two clients who were taking our research Nippon Life and the Japanese Postal Savings Fund. My meeting with Nippon Life was fairly straight forward. They knew what our forecast was that Japan was moving into a bubble top - the 1989.95 turning point. What they wanted to discuss was hedging their portfolio to survive what they agreed was shaping up to be a major high.

At that meeting, I had asked the size of the portfolio, because of my experience in dealing with the Arabs. One had to know the size of the position because any advice would have to take that into consideration.

Nippon Life told me "Ichi Cho" which is 1 trillion. I assumed we were taking yen so I converted that in my head and thought this was no so big, a mere 10 billion dollars. Now they laughed at me. They replied, "Ichi cho dollar!" I looked at them and asked again. "Ichi cho dollar?" They again said politely - yes (which in Western terms would have been followed by "you idiot.")

This was the first trillion dollar portfolio I had ever encountered. This was obviously becoming a very serious project. After our discussing of agreeing to advise on the hedging strategy, I left it to them to get their required approval from the LDP.

Meanwhile, my next meeting was with the Japanese Postal Saving Fund, who had also been a client at the subscription level. I had not obviously done my homework on any investigation of portfolio size. I was just floored by the meeting with Nippon Life. I was to get the second punch real quick. I was perhaps less shocked when I found out that this portfolio was now at least 50% bigger than Nippon Life.

The Japanese Postal Savings Fund had contracted out chunks of money to various banks to be invested. They too were keenly interested in understanding how to hedge. At this point, I was staring at giving strategic advice of hedging almost the total amount of half the entire US National Debt at the time. This was serious stuff.

I had dealt with billion dollar positions with the Arabs in the mid-80s back when the largest hedge fund was but a mere 100 million. By the end of the 80s, I was now into the trillions of dollars. What I was facing was indeed beyond description. It would take every trick in the book I every learned not just to advise on such capital tsunami events, but it would take every talent I could muster to program a computer to monitor monster positions.

My worst possible nightmare was relieved by the LDP. They squashed all hedging. I was told by Nippon Life that the government asked them not to hedge, because in their view, they would make the market decline.

The LDP, as most politicians, never once understood what markets are all about. They failed to understand what makes the market collapse is not the sellers, it is the lack of buyers. Once you run out of buyers, then the longs start to take profits. As it then comes down, you begin to scare the herd of longs and once you do that, you end up with the biggest selling pressure of all - panic. Once all the longs want to get out, the party is over. You can outlaw short selling. You can outlaw hedging. But you cannot outlaw the good old liquidation selling at any price. This is now into the survival of the fittest.

The LDP prevented me from having to take on the biggest hedging projects in the history of man. Thank you for that, for I probably would have died 10 years ago from the added stress. But what they failed to realize, you had two of the biggest portfolios and they were expressing common sense. Enough was just enough, and they wanted to lock in some of these outrageous bubble top profits. People were even arguing that the land values in Tokyo had now exceeded all of the entire United States combined. Embassies such as Australia, were smart enough to sell their land holdings in Tokyo and just rent.

The LDP would not allow the free markets to function. You cannot imagine the economic damage the LDP caused. The sheer losses that took place in Japan were sickening. What I ended up doing in Japan, was more rescue work because the LDP had screwed up the economy thinking they could just dictate the outcome. The Postal Savings Fund, the largest portfolio in the world in 1989, was used to support debt to keep interest rates low, at a tremendous cost to the people of Japan.



Tsunami in Japan that washed away the LDP became self-evident that we were in the middle of a major political change that was taking place also with the same turning point on the Economic Confidence Model 1989.95. It was the peak in the Japanese markets and the economy without doubt. What I witnessed with squashing the hedging projects of those who had looked out the window and thought it might be time to hedge the bet, was the power shift in the LDP to try to prevent the decline, rather than work with the cycle. The first warning sign in Japanese politicians came early in 1993, where the LDP lost power for one of those fleeting moments in time to what emerged as an eight-party coalition. The LDP had still remained the largest party by far, but the warning of its demise was now appearing on the horizon. But like most, they ignored the trend and made the excuse that they were still the dominant power.

The warning signs were there if one just would look with their eyes open. The LDP was losing ground little by little. However, it was in 2005 when they claimed victory, but lied to the public and ignored what had even taken place.

The election of 2005 produced a 2/3rds majority for the LDP. But what they did not bother paying attention to was the rhetoric that won that election. Junichiro Koizumi won the election that is true, but his promise was he ran on an anti-LDP ticket that claimed he was going to turn the LDP on its head and introduce free-market policies.

The sweeping changes that have now arrived are not as far-reaching as many may yet contemplate. The view of the DPJ's new agenda is perhaps trying to patch up the mess of the LDP, but I doubt that there is a real nerve to do the right thing. Many people are just trying to hold on to what they had, with pensions, jobs, and health-care, while worrying about employment for their children. Japan is highly socialized and the pension problem there too is a real nightmare for the future.

The new Democratic Party has pledged a list of values:

- (1) No increase in consumption tax for the next 4 years
- (2) Pay ¥26,000 per month (\$280) as a subsidy for each child up to 15
- (3) End the "bureaucrat-led" system of government returning it back to the people by elected officials increasing the powers of the Prime Minister and ending the retirement of bureaucratic elite to those corporate jobs that messed up truly a lot of companies I saw
- (4) End the outrageous tolls on the highways that would have caused a revolution in New York long ago.
- (5) Clean up the bad air by reducing the greenhouse gases by 25% from 1990 levels by 2020.

The regulation in Japan is beyond all belief, with so many layers of government that need to be visited just to get a single approval. But the control of the economy by Bureaucrats, has screwed up Japan very similarly as was caused in Russia for different reasons.



Hirotsuki Castle - Japan

The Japanese people have been oppressed for so long, what is starting to emerge is a new and vibrant culture. The turning point was truly 1976. After that date, we begin to see the rise in Japanese corporate power and trade. By the mid 1980's, the Japanese have purchased about 33% of the entire US National Debt in an effort directed by the LDP to ease trade friction. The Japanese emerge from the centuries of being isolationists, into the full member status of the global economy.

The Japanese began to invest in the US real estate market even buying Rockefeller Center in New York City. To the Japanese, it was real estate that was the true symbol of wealth, and to understand that, one must also consider that the Japanese people had also been merely slaves in a feudal system. Yet, Japan itself was a small island and the one thing that was truly scarce was land. So to the Japanese, land was wealth.

The LDP dictated to the private sector and the bureaucrats secured big paying jobs in corporate Japan as retirement bonuses. It is fundamental that some companies like Yakult were truly run by the LDP pulling strings behind the scenes.

The free markets did not exist in Japan and this is why what we are looking at is a near 26 year Great Depression that has yet to come to an end in Japan. The ideal target is also 2016, which is the peak of the next 8.6 year wave on the Economic Confidence Model. The LDP dictated everything and that is why the Japanese economy imploded.

My personal experience in Japan I will reveal in a book. For the real story of the LDP has been suppressed for so long. It is not a subject that the Japanese feel free to discuss, for they still follow the line of what some have called "the tall poppy syndrome" whereas the poppy that grows higher than the others, gets its head cut off.

Despite the image of Japan being a real democracy, the people tolerated suppression for the good of the state. Individualism in Japan was rare, and feared among Japanese, yet strangely admired among foreigners.

The LDP prevented free markets and for that reason, the "lost decade" unfolded and is turning into the "lost few decades" in Japan. The system is highly socialistic, and the rapidly aging population is putting the demands upon the finances of the state.

The political loss for the LDP right now is a signal of the last throes of a dying system. Japan is the second largest economy in the world, and it too is in serious and deep trouble.

~ 2016 ~

The year 2016 should be a watershed event around the world. The correlation that is shaping up among a host of markets like gold and economies globally, is just truly astonishing. This is where the end of this economic decline is likely to take place. But we may also see that with gold at least at the \$5,000 level. This is a reflection of a complete economic implosion. We should see gold rise also sharply in Japanese yen for the Japanese are also keenly aware of gold's roll. We should expect to see major buying of gold by the Japanese population itself.

What the LDP did to Japan cannot be put in words lightly. Its attack upon the foreign houses like Credit Swiss and even our firm, are indicative of trying to shift blame away from the political nightmare. Our staff in Japan, including Japanese themselves, suspected that what was done to Princeton was politically motivated and deliberately put Japanese companies at risk by allowing the notes to be issued after the case began to avoid any insurance problems in Japan that the government would have been liable forcing Japan to file suit against Republic Bank.

Did JAPAN ATTACK Foreign Banks & Broker-Dealers For Political Reasons?

There has been a nagging question that has persisted among former employees of our Princeton Economics. Did the Japanese Government Conspire with the US Government to shut Princeton Economics?

One of the strangest aspects of my case is that the allegations deliberately lied about basic structural facts. (1) I did not own Princeton Economics alone, and (2) while we did manage money in three public funds two for Deutsche Bank and in Australia and Hong Kong, the third was in London, we were not managing money for the Japanese. We had issued unsecured notes for either a fixed 4% rate of return in yen known as the carry trade converting to dollars and earning 8%+ and no trading plus or minus flowed to a note holder. So there could have been no managed money. The second type of note was issued with the very request and approval of the Japanese Ministry of Finance that we purchased pre-existing portfolios of Japanese stocks that had fallen 30-50% from Japanese corporations at their original cost with a unsecured note. We sold the portfolios in Japan, took the yen, and converted that to dollars. Again, no profits of losses flowed to the note holders for had that been the case, then they would have had to report the loss taken when we first sold the portfolios in Japan. They did not show those losses, for the whole purpose of this was a bailout.

In fact, the majority of the notes were left in street-name at our broker-dealer in Japan, and were never even issued. Just as you may buy stock in IBM, the shares are not registered in your name unless you take your delivery. It was the receiver Alan Cohen and his lawyer at O'Melveny & Myers, LLP, Tancred Schiavoni, who covertly had the notes issued after the case began to create their own fees and protect their jurisdiction. The fact that we had paid \$5 million for insurance in Japan as part of the Regulation, meant that all the note holders were 100% insured by Japan. By issuing the notes, Cohen & Schiavoni eliminated the Japanese insurance, who should have in turn filed suit against the NY Banking house - Republic National Bank.

The real strange behind-the-scene machinations, come in the form of the very Japanese Government issuing a letter to Republic claiming that Princeton was to have \$10 billion on deposit at the bank.

In or about May of 1998, I had met with Dov Schlein the President of Republic National Bank. They tried to solicit me to bring over \$10 billion from Japanese corporations and offered a guarantee from the holding corporation. I had sent an email to the Japan office informing them of the offer, but I told them I was not about to tell the Japanese to bring over that kind of money just so they could lend it out to Russia.

This is where things got very, very interesting. Republic was involved in a investment company in Russia then spear-headed by the name of Hermitage. We had discussed the Russian market and I told them that our model was pointing to a huge collapse on the horizon.

Republic had invited me to the IMF (International Monetary Fund) dinner where they had rented the entire National Gallery in Washington, DC. Everybody who was anybody was there, both past and present politicians and that included Paul Volker. They were at that time trying to impress upon me that the real way to do business was without the risk. They believed they had the inside track at the IMF and the scheme was then to keep the loans were flowing to Russia, then the New York crowd could buy the debt paying huge rates of interest, assuming that the free market pricing was wrong since they controlled the inside track.

I rejected the deal, and again warned them that Russia was going to collapse. In August 1998, I gave a lecture to our clients in London. The London Financial Time attended and ran a story on the front page of the Second Section reporting that I had delivered a forecast that Russia would collapse in about 30 days. When it did, that is when the whole CIA thing came into play reported by former employees.

In March of 1999, the Investment Banks were now scheming to make up for losses in Russia after they convinced the Fed to bail out a hedge fund no less. You see, the Long Term Capital Management fund was also in for the ride on the Russian debt. So when everything did collapse in the September of 1998, the contagion was far greater than even I had expected insofar as volatility was concerned. The magnitude was at least double if not approaching three times greater than anything I had seen in my life-time and certainly in historical research since the Currency Crisis of 1931.

It was the degree of leverage that was off-the-charts with the derivatives used at Long Term Capital and Goldman Sachs. The real bailout was to the Investment Banks because the positions blown up by the derivatives, exposed the likes of Goldman Sachs and others perhaps for the first time. What happened in 2007, was merely a repeat with AIG at the new center still using derivatives.

The scheme was now targeting Japan and they knew that at the end of the March fiscal year, the Japanese brought back their money, and reinvested every April. Even our own fixed rate notes were typically redeemed every year.

The Investment Banks were wise to this flow of capital and decided they would take positions for the end of March, force the spread higher, and thus scalp the Japanese 100 points of more over the roll-over.

I stood up at our Conference held at the Imperial Hotel in Japan that early March. I informed the Japanese that they were being targeted. I did not publicly state who was the actual banks targeting them, just that the manipulators were now targeting them. I told everyone in Japan to fix the rate for selling the yen to go back to dollars in April to defeat the manipulation. They did, and the New York crowd was not pleased. They lost a shit-load of money.

There is no doubt that the NY Investment Banks hated my guts. They did not like me telling clients that there were organized manipulations going on. The head trader from AIG even flew from London to try to get me to not discuss publicly about such things. I told him, I never revealed names.

While the US side was brewing against me and Princeton, the Japanese Government was not pleased either because I publicly also warned that the Postal Savings Fund was in trouble and that the Government would guarantee all funds, but the dictatorial running of the economy was preventing the recovery. The real shocker, I revealed the real controversial forecast, that the LDP was going into a downward spiral that would end with their defeat. That, in Japan, had crossed the line as far as the government was concerned.

Staff in Japan believed that the letter from the Japanese Government to Republic claiming they wanted to verify we had now \$10 billion on deposit, was an intentional move to start the ball rolling. It is clear that Republic took funds then for the whole bank was being sold to HSBC for \$10 billion. In today's dollars, it was like asking to verify that we had \$100 billion.

The Japanese Government then issued a retraction (see letter), but it was too late. Republic had already taken money and then told the Fed their own employees had conspired with me to hide trading losses from the Japanese, when it was the illegal trading by Republic in our accounts that were proprietary, and were never the trading accounts for any Japanese.

I do not know what to believe anymore. All I do know, is they never served the corporations and that they never allowed Princeton Economics to hire lawyers, and that alone meant that the judgments in the courts were all illegal.

Federal Rules of Civil Procedure

Rule 65(a) Preliminary Injunction

- (1) Notice. The court may issue a preliminary injunction only on notice to the adverse party.

I also attach an affidavit of Martin Unger, my New York counsel, who affirmed under oath, he was never hired to represent the corporations. Even when Judge Richard Owen took all my lawyers away, he made it a point to note that they were not counsel for the corporations, SEC v Pei, 84 FSupp2d 443, 447 (SDNY 2000). They do not obey their own laws.

I find it curious that all governments attack the foreign broker-dealers and banks to try to blame them for their domestic problems. The trial of the Swiss Credit banker and his guilty verdict claiming he committed a fraud by imply that the mortgage backed securities they purchases were somehow not risky because they were back by the federal government, is ironic.

Here we have the US firms that created this nightmare, Goldman Sachs, J.P. Morgan, and AIG, who also used the same sales pitch and nobody at those firms is criminally prosecuted and facing nearly life in prison, yet those who worked for a foreign bank who said the same things, are targets.

This is what is wrong with the entire legal system worldwide. The Japanese LDP invited foreign houses to help bailout the problem in Japan. We certainly could not issue a single note without the individual approval of the Japanese Ministry of Finance or no portfolio could have been purchased.

When the scheme they request is put in place, then it becomes the entire problem of politics when they get in trouble and turn to blame foreigners for what the themselves requested and approved.

It is unfortunate, but what was set in motion by Karl Marx was accepted with open arms around the world not to help the poor or really exploit the rich, but to further the political power of government. It made supermen out of politicians and handed them the staff of power. They believed their own bullshit and thought they could dictate to the people and compel them to do as they so decree at any moment. They knew nothing of how economies function, and assume that their sheer will was good enough. Marx made all politicians demi-gods.

Japan is now in the final stages of its 26 year Economic Great Depression. The precise calculation is 25.8 years (3 8.6 year cycles) This brings us to late October 2015. We had better hold on to our seats, for what we are going to see in the years ahead, is a full blown economic disaster. Marxism is collapsing and many are too stupid to understand that it is the unsupported obligations that cuts off our future. Japan is starting to show its new unrest, and that is going to lead toward a revaluation of western ideas economically.

Just as Obama is trying to fix things with more of the very thing that created the problem, the same trend is emerging in Japan. People want a future, and they will listen to anyone who promises to make it all better.

The Prime Ministers of Japan in the Meiji Wave up to the bubble top 1989.95

Name	Party	Term	Name	Party	Term
Ishikawa Junji (1st time)	Liberal Democratic	1889-91	Ango Nobuhide	Liberal Democratic	1909-10
Kuroda Kiyomasa	Liberal Democratic	1890-93	Yoshihide Shigemitsu	Liberal Democratic	1940-41
Arifudate Arifudate (1st time)	Liberal Democratic	1890-91	Kono Genzo	Liberal Democratic	1940-41
Matsuda Katsumasa (1st time)	Liberal Democratic	1890-91	Kono Genzo	Liberal Democratic	1940-41
Ueda Shinzou (2nd time)	Liberal Democratic	1891-92	Yoshida Shigeru (1st time)	Liberal Democratic	1946-47
Mitsuda Katsumasa (2nd time)	Liberal Democratic	1891-92	Yoshida Shigeru (2nd time)	Liberal Democratic	1947-48
Ueda Shinzou (3rd time)	Liberal Democratic	1892-93	Yoshida Shigeru (3rd time)	Liberal Democratic	1948-49
Ueda Shinzou (4th time)	Liberal Democratic	1893-94	Yoshida Shigeru (4th time)	Liberal Democratic	1949-50
Ueda Shinzou (5th time)	Liberal Democratic	1894-95	Yoshida Shigeru (5th time)	Liberal Democratic	1950-51
Ueda Shinzou (6th time)	Liberal Democratic	1895-96	Yoshida Shigeru (6th time)	Liberal Democratic	1951-52
Ueda Shinzou (7th time)	Liberal Democratic	1896-97	Yoshida Shigeru (7th time)	Liberal Democratic	1952-53
Ueda Shinzou (8th time)	Liberal Democratic	1897-98	Yoshida Shigeru (8th time)	Liberal Democratic	1953-54
Ueda Shinzou (9th time)	Liberal Democratic	1898-99	Yoshida Shigeru (9th time)	Liberal Democratic	1954-55
Ueda Shinzou (10th time)	Liberal Democratic	1899-00	Yoshida Shigeru (10th time)	Liberal Democratic	1955-56
Ueda Shinzou (11th time)	Liberal Democratic	1900-01	Yoshida Shigeru (11th time)	Liberal Democratic	1956-57
Ueda Shinzou (12th time)	Liberal Democratic	1901-02	Yoshida Shigeru (12th time)	Liberal Democratic	1957-58
Ueda Shinzou (13th time)	Liberal Democratic	1902-03	Yoshida Shigeru (13th time)	Liberal Democratic	1958-59
Ueda Shinzou (14th time)	Liberal Democratic	1903-04	Yoshida Shigeru (14th time)	Liberal Democratic	1959-60
Ueda Shinzou (15th time)	Liberal Democratic	1904-05	Yoshida Shigeru (15th time)	Liberal Democratic	1960-61
Ueda Shinzou (16th time)	Liberal Democratic	1905-06	Yoshida Shigeru (16th time)	Liberal Democratic	1961-62
Ueda Shinzou (17th time)	Liberal Democratic	1906-07	Yoshida Shigeru (17th time)	Liberal Democratic	1962-63
Ueda Shinzou (18th time)	Liberal Democratic	1907-08	Yoshida Shigeru (18th time)	Liberal Democratic	1963-64
Ueda Shinzou (19th time)	Liberal Democratic	1908-09	Yoshida Shigeru (19th time)	Liberal Democratic	1964-65
Ueda Shinzou (20th time)	Liberal Democratic	1909-10	Yoshida Shigeru (20th time)	Liberal Democratic	1965-66
Ueda Shinzou (21st time)	Liberal Democratic	1910-11	Yoshida Shigeru (21st time)	Liberal Democratic	1966-67
Ueda Shinzou (22nd time)	Liberal Democratic	1911-12	Yoshida Shigeru (22nd time)	Liberal Democratic	1967-68
Ueda Shinzou (23rd time)	Liberal Democratic	1912-13	Yoshida Shigeru (23rd time)	Liberal Democratic	1968-69
Ueda Shinzou (24th time)	Liberal Democratic	1913-14	Yoshida Shigeru (24th time)	Liberal Democratic	1969-70
Ueda Shinzou (25th time)	Liberal Democratic	1914-15	Yoshida Shigeru (25th time)	Liberal Democratic	1970-71
Ueda Shinzou (26th time)	Liberal Democratic	1915-16	Yoshida Shigeru (26th time)	Liberal Democratic	1971-72
Ueda Shinzou (27th time)	Liberal Democratic	1916-17	Yoshida Shigeru (27th time)	Liberal Democratic	1972-73
Ueda Shinzou (28th time)	Liberal Democratic	1917-18	Yoshida Shigeru (28th time)	Liberal Democratic	1973-74
Ueda Shinzou (29th time)	Liberal Democratic	1918-19	Yoshida Shigeru (29th time)	Liberal Democratic	1974-75
Ueda Shinzou (30th time)	Liberal Democratic	1919-20	Yoshida Shigeru (30th time)	Liberal Democratic	1975-76
Ueda Shinzou (31st time)	Liberal Democratic	1920-21	Yoshida Shigeru (31st time)	Liberal Democratic	1976-77
Ueda Shinzou (32nd time)	Liberal Democratic	1921-22	Yoshida Shigeru (32nd time)	Liberal Democratic	1977-78
Ueda Shinzou (33rd time)	Liberal Democratic	1922-23	Yoshida Shigeru (33rd time)	Liberal Democratic	1978-79
Ueda Shinzou (34th time)	Liberal Democratic	1923-24	Yoshida Shigeru (34th time)	Liberal Democratic	1979-80
Ueda Shinzou (35th time)	Liberal Democratic	1924-25	Yoshida Shigeru (35th time)	Liberal Democratic	1980-81
Ueda Shinzou (36th time)	Liberal Democratic	1925-26	Yoshida Shigeru (36th time)	Liberal Democratic	1981-82
Ueda Shinzou (37th time)	Liberal Democratic	1926-27	Yoshida Shigeru (37th time)	Liberal Democratic	1982-83
Ueda Shinzou (38th time)	Liberal Democratic	1927-28	Yoshida Shigeru (38th time)	Liberal Democratic	1983-84
Ueda Shinzou (39th time)	Liberal Democratic	1928-29	Yoshida Shigeru (39th time)	Liberal Democratic	1984-85
Ueda Shinzou (40th time)	Liberal Democratic	1929-30	Yoshida Shigeru (40th time)	Liberal Democratic	1985-86
Ueda Shinzou (41st time)	Liberal Democratic	1930-31	Yoshida Shigeru (41st time)	Liberal Democratic	1986-87
Ueda Shinzou (42nd time)	Liberal Democratic	1931-32	Yoshida Shigeru (42nd time)	Liberal Democratic	1987-88
Ueda Shinzou (43rd time)	Liberal Democratic	1932-33	Yoshida Shigeru (43rd time)	Liberal Democratic	1988-89
Ueda Shinzou (44th time)	Liberal Democratic	1933-34	Yoshida Shigeru (44th time)	Liberal Democratic	1989-90
Ueda Shinzou (45th time)	Liberal Democratic	1934-35	Yoshida Shigeru (45th time)	Liberal Democratic	1990-91
Ueda Shinzou (46th time)	Liberal Democratic	1935-36	Yoshida Shigeru (46th time)	Liberal Democratic	1991-92
Ueda Shinzou (47th time)	Liberal Democratic	1936-37	Yoshida Shigeru (47th time)	Liberal Democratic	1992-93
Ueda Shinzou (48th time)	Liberal Democratic	1937-38	Yoshida Shigeru (48th time)	Liberal Democratic	1993-94
Ueda Shinzou (49th time)	Liberal Democratic	1938-39	Yoshida Shigeru (49th time)	Liberal Democratic	1994-95
Ueda Shinzou (50th time)	Liberal Democratic	1939-40	Yoshida Shigeru (50th time)	Liberal Democratic	1995-96
Ueda Shinzou (51st time)	Liberal Democratic	1940-41	Yoshida Shigeru (51st time)	Liberal Democratic	1996-97
Ueda Shinzou (52nd time)	Liberal Democratic	1941-42	Yoshida Shigeru (52nd time)	Liberal Democratic	1997-98
Ueda Shinzou (53rd time)	Liberal Democratic	1942-43	Yoshida Shigeru (53rd time)	Liberal Democratic	1998-99
Ueda Shinzou (54th time)	Liberal Democratic	1943-44	Yoshida Shigeru (54th time)	Liberal Democratic	1999-00
Ueda Shinzou (55th time)	Liberal Democratic	1944-45	Yoshida Shigeru (55th time)	Liberal Democratic	2000-01
Ueda Shinzou (56th time)	Liberal Democratic	1945-46	Yoshida Shigeru (56th time)	Liberal Democratic	2001-02
Ueda Shinzou (57th time)	Liberal Democratic	1946-47	Yoshida Shigeru (57th time)	Liberal Democratic	2002-03
Ueda Shinzou (58th time)	Liberal Democratic	1947-48	Yoshida Shigeru (58th time)	Liberal Democratic	2003-04
Ueda Shinzou (59th time)	Liberal Democratic	1948-49	Yoshida Shigeru (59th time)	Liberal Democratic	2004-05
Ueda Shinzou (60th time)	Liberal Democratic	1949-50	Yoshida Shigeru (60th time)	Liberal Democratic	2005-06
Ueda Shinzou (61st time)	Liberal Democratic	1950-51	Yoshida Shigeru (61st time)	Liberal Democratic	2006-07
Ueda Shinzou (62nd time)	Liberal Democratic	1951-52	Yoshida Shigeru (62nd time)	Liberal Democratic	2007-08
Ueda Shinzou (63rd time)	Liberal Democratic	1952-53	Yoshida Shigeru (63rd time)	Liberal Democratic	2008-09
Ueda Shinzou (64th time)	Liberal Democratic	1953-54	Yoshida Shigeru (64th time)	Liberal Democratic	2009-10
Ueda Shinzou (65th time)	Liberal Democratic	1954-55	Yoshida Shigeru (65th time)	Liberal Democratic	2010-11
Ueda Shinzou (66th time)	Liberal Democratic	1955-56	Yoshida Shigeru (66th time)	Liberal Democratic	2011-12
Ueda Shinzou (67th time)	Liberal Democratic	1956-57	Yoshida Shigeru (67th time)	Liberal Democratic	2012-13
Ueda Shinzou (68th time)	Liberal Democratic	1957-58	Yoshida Shigeru (68th time)	Liberal Democratic	2013-14
Ueda Shinzou (69th time)	Liberal Democratic	1958-59	Yoshida Shigeru (69th time)	Liberal Democratic	2014-15
Ueda Shinzou (70th time)	Liberal Democratic	1959-60	Yoshida Shigeru (70th time)	Liberal Democratic	2015-16
Ueda Shinzou (71st time)	Liberal Democratic	1960-61	Yoshida Shigeru (71st time)	Liberal Democratic	2016-17
Ueda Shinzou (72nd time)	Liberal Democratic	1961-62	Yoshida Shigeru (72nd time)	Liberal Democratic	2017-18
Ueda Shinzou (73rd time)	Liberal Democratic	1962-63	Yoshida Shigeru (73rd time)	Liberal Democratic	2018-19
Ueda Shinzou (74th time)	Liberal Democratic	1963-64	Yoshida Shigeru (74th time)	Liberal Democratic	2019-20
Ueda Shinzou (75th time)	Liberal Democratic	1964-65	Yoshida Shigeru (75th time)	Liberal Democratic	2020-21
Ueda Shinzou (76th time)	Liberal Democratic	1965-66	Yoshida Shigeru (76th time)	Liberal Democratic	2021-22
Ueda Shinzou (77th time)	Liberal Democratic	1966-67	Yoshida Shigeru (77th time)	Liberal Democratic	2022-23
Ueda Shinzou (78th time)	Liberal Democratic	1967-68	Yoshida Shigeru (78th time)	Liberal Democratic	2023-24
Ueda Shinzou (79th time)	Liberal Democratic	1968-69	Yoshida Shigeru (79th time)	Liberal Democratic	2024-25
Ueda Shinzou (80th time)	Liberal Democratic	1969-70	Yoshida Shigeru (80th time)	Liberal Democratic	2025-26

IN THE UNITED STATES DISTRICT COURT
FOR THE SOUTHERN DISTRICT OF NEW YORK

SECURITIES AND EXCHANGE COMMISSION,

Plaintiff,

v.

PRINCETON ECONOMICS INTERNATIONAL,
LTD., PRINCETON GLOBAL MANAGEMENT,
LTD., and MARTIN A. ARMSTRONG,

Defendants.

COMMODITY FUTURES TRADING COMMISSION,

Plaintiff,

v.

PRINCETON GLOBAL MANAGEMENT, LTD.,
PRINCETON ECONOMICS INTERNATIONAL,
LTD., and MARTIN A. ARMSTRONG,

Defendants.

AFFIDAVIT OF MARTIN P. UNGER

STATE OF NEW YORK)
 : ss:
COUNTY OF NASSAU)

I, MARTIN P. UNGER, being duly sworn, deposes and says:

1. I am a member of the law firm Cerrubian Balin Adler & Hyman, LLP, 90 Merrick Avenue, East Meadow, New York 11554, and licensed to practice law in the

State of New York. I submit this affidavit in support of Martin A. Armstrong's ("Armstrong") pleadings in the above-captioned actions. I am fully competent to submit this affidavit based on my personal knowledge and best recollection of the information set forth herein, unless otherwise indicated. If called to testify, I would state as follows:

2. I am a former partner of the New York City law office of Blank Rome Tenzer & Greenblatt LLP ("Tenzer Greenblatt"). At some point prior to September 13, 1999 through mid-2000, Tenzer Greenblatt served as Armstrong's counsel in civil enforcement suits brought against him in the United States District Court for the Southern District of New York by the United States Securities and Exchange Commission ("SEC"), captioned *SEC v. Princeton Economics International, Ltd, et al.*, No. 99 Civ. 9667 (RO), and by the United States Commodity Futures Trading Commission ("CFTC"), captioned *CFTC v. Princeton Global Management, Ltd, et al.*, No. 99 Civ. 9669 (RO) ("Civil Actions"). I was the lead attorney at Tenzer Greenblatt who headed up the firm's representation of Armstrong in the Civil Actions.

3. I am aware that two foreign corporations, Princeton Economics International, Ltd and Princeton Global Management, Ltd, also were named as defendants by the SEC and the CFTC in each of the Civil Actions. Tenzer Greenblatt did not represent either of these corporations in the Civil Actions or in any other capacity. In the Civil Actions, Tenzer Greenblatt's representation at all times was limited to Armstrong and no one else.

Affidavit of Martin P. Unger

Case No. 99 Civ. 9667-RO

Case No. 99 Civ. 9669-RO

Under penalties of perjury, I declare that the foregoing is true and correct to the best of my knowledge, information and belief.

Dated: September 1, 2004

Martin P. Unger

Sworn to before me this
7th day of September 2004

Notary Public
NATALYA RAVICH
Notary Public, State Of New York
No. 02110057493
Qualified in Nassau County
Commission Expires December 10, 2005

Financial Supervisory Agency
3-2-1 Kasumigaoshi Chiyoda-ku Tokyo
Japan
Telephone 813-3581-6765
FAX 813-3251-2154

August 31, 1999
Ms. Anne T. Vitale
Managing Director
Deputy General Counsel
Republic National Bank of New York
C/O Mr. Thomas A. Chaves
Assistant Vice President
Federal Reserve Bank of New York

Dear Ms. Vitale

I want to correct the issued amount and the outstanding amount of the Princeton Notes stated in my FAX as of 19 August, 1999.
The correct issued amount of the Princeton Notes is about three billion US Dollars.
The correct outstanding amount of the Princeton Notes is one billion US Dollars.

Best regards

Keiji Setoguchi
Financial Inspector
Inspection Department
Financial Supervisory Agency
Japan